

深圳市创纪科技有限公司
产品承认书 Product Specification

客户名称 Customer: _____

客户部件号Customer Part No: _____

产品名称Product Name: 控制杆 JOYSTICK

产品型号Item No: JT-3590-R

规格书确认 Specification for Approval				
确认者Approval by: _____ 日期Date: _____				
若确认此规格书, 请签复此页. Please return this copy as a certification of your approval.				
规格书更改记录Record of Change Specification				
版本Version	修改总项 History Count	明细Details	日期Date	拟制 Prepared
V1.1				

拟制Prepared by:	审核Checked by:	批准Approved by:
赵正春	李梅	Tim Lau

生产地:中国Country of Origin: China
 深圳市龙岗区龙城街道龙城金地中央3栋D座3605室
 Room 3605, block D, building 3, Longcheng Jindi central,
 Longcheng street, Longgang District, Shenzhen
 电话: Tel: (0755) 83861182
 邮箱: E-Mail: tim1698@126.com
 网址: Website: www.genesis.net.cn

产品规格:

摇杆球: 35mm
杆长: 90mm (加长杆)
倾斜角度: +-8.5度
灵敏度: 5ms max 以3-4 次/秒的频率施加正常力于按钮上, 操作之动作则可测出“ON”、“OFF”之功能。
使用微动: ZING EAR
负荷寿命: 1,000,000次 (在带负荷的条件下, 速度15次/分, 在寿命试验设备上连续转换 1,000,000 次)。
机械寿命: 10,000,000次 (在不带负荷, 操作频率: 30-60次/分), 操作力变化范围: 初期值±30%。
产品外观尺寸: L: 95mm ; W: 60mm ; H: 116mm

产品尺寸:

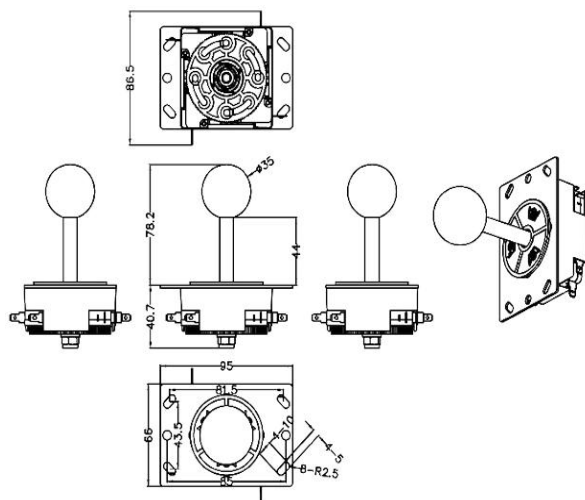

产品参数:

开关接线口规格	DC30V. 100mA	电压: (同端子间)	AC1000V
开关接线口接触电阻:	1Ω 以下(在1A 电压降下法)	电压: (端子和接线之间)	AC1500V
使用温度范围:	-20°C 至+65°C	绝缘电阻: (同端子之间)	100Ω 以上(DC500 兆)
开关频率:	30次/分钟	绝缘电阻: (同端子接线之间)	100Ω 以上(DC500 兆)

注意事项:

1. 八角档圈, 带片微动开关, 重手感 (使用弹簧1.0) ;
 2. 球头: 红色、黑色、白色、橙色等多种选择 ;
 3. 可配黑色套筒, 防尘片2PCS, 螺母防滑垫 ;
 4. 左右摇杆线材按照客户图纸生产, 商量确认 ;
- 包装: 摇杆隔板包装, 100 个/箱, 包含防尘片、球头、线材 ;

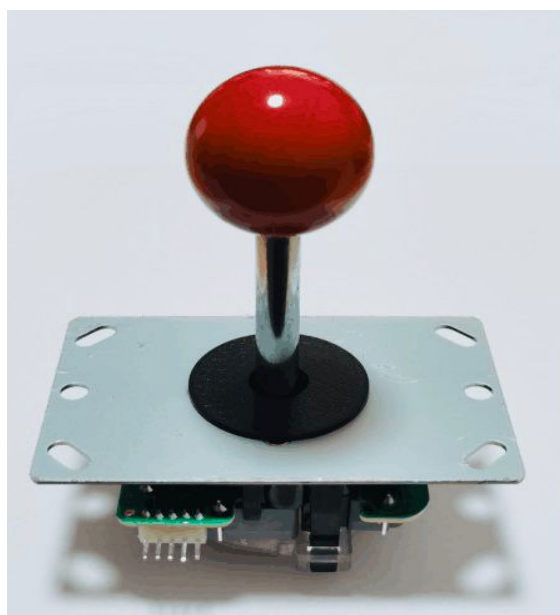

1.一般特性 General Characteristics:

1.1 适用范围 Application	该规格书指微动开关的一般使用范围 This specification is applied to the micro switch for general applications.
1.2 使用温度范围 Operating Temperature Range	-25°C to +125°C
1.3 使用相对湿度范围 Operating Relative Humidity Range	≤96% RH, +40°C
1.4 实验条件 Test Conditions	若没有特别说明，则试验大气条件如下： Unless otherwise specified, the atmospheric conditions for making measurements and tests are as follows: 环境温度 Ambient Temperature: 5-35°C 大气压力 Air Pressure: 86-106 Kpa 860-1060 mbar 相对湿度 Relative Humidity: 45-85% RH

2.外观，结构及尺寸 Appearance, Structure and Dimensions:

2.1 外观 Appearance	产品外观良好，无锈蚀、裂纹和镀层缺陷。 The switch shall have good finishing, and no rust, crack or plating defects.
2.2 结构及尺寸 Structure and Dimensions	参见产品图纸 Refer to individual product drawing
2.3 标识 Markings	参见产品图纸。 Refer to individual product drawing.
2.4 获得的安全认证及档案号 Safety Certificate Obtained & File No.	ENEC: File No.2832; UL: file NO.E89885 CQC: File No. CQC07003019079.

3.额定负荷及寿命 Ratings and Life:

额定负荷 Ratings	机械寿命 Operating life without load	负荷寿命 Operating life with load
参见产品图纸	1,000,000 次cycles	参见产品图纸

4.电气性能 Electrical Characteristics:

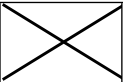
	项目 Item	标准 Criteria	实验方法 Test Method
4.1	绝缘电阻 Insulation Resistance	100MΩ Min.	在相互绝缘的所有端子之间及各接线端子与外露的非载流金属零件之间加载 500V 直流电，持续时间 30 ± 5 秒。 500V DC voltage is applied between each pair of terminals, and between the terminal and the metal frame for 30 ± 5 Sec.
4.2	抗电强度 Dielectric Voltage	无击穿现象发生 No dielectric breakdown shall occur	在相互绝缘的所有接线端子之间加载 1000V(50-60Hz，泄漏电流 10mA)交流电，各接线端子与外壳或非载流金属零件之间加载 1500V(50-60Hz，泄漏电流 10mA)交流电，持续时间 10 ± 2 秒。 1000V(50-60HZ, 10mA) alternate current load is applied between open terminals connected with wires; or 1500V(50-60HZ,10mA) alternate current load is applied between frame and terminal or between metal parts, for 10 ± 2 Sec.

5.机械性能 Mechanical Characteristics:

	项目 Item	标准 Criteria	实验方法 Test Method
--	---------	-------------	------------------

5.1	操作力 Operating Force	见图纸 See Drawing	在操作元件末端沿操作方向均匀施加静载荷，使操作元件 转换到动作位置 A static load shall be applied to the tip of actuator in operating direction to change the component to operating position
5.2	回复力 Releasing Force	见图纸 See Drawing	在操作元件末端沿操作方向均匀减少静载荷，使操作元件从动作位置转换到释放位置。 A static load shall be reduced to the tip of actuator in operating direction to change component from operating position to release position.
5.3	操作位置 Operating Position	见图纸 See Drawing	开关发生转换时，操作元件末端到开关安装孔中心的距离 The distance from the end of operating component to the center of mount hole when switch is being transformed
5.4	行程 Travels	见图纸 See Drawing	从自由位置到动作位置的距离。 The distance from release position to operating position.
5.5	差程 Differential Travel	见图纸 See Drawing	从动作位置到释放位置的距离。 The distance from operating position to release position
5.6	接线端强度 Terminal Strength	端子无松动，损坏及绝缘层的破裂 Shall be free from terminal looseness, damage and insulator breakage. 电气性能应符合第 4.1-4.2 部分的要求 The electrical performance requirements specified in Section 4.1-4.2 shall be satisfied.	以2550gf/25N 作用力沿轴向逐渐施加于接线端末端，作用力方向为离开开关向外指向，保持 60 秒，每个接线端子测量一次。 A static load of 2550gf/25N shall be applied to the tip of terminal in a desired direction for 60 Sec. The test shall be done once per terminal.

6.寿命试验 Durability Characteristics:

	项目 Item	标准 Criteria	实验方法 Test Method
6.1	机械寿命 Operating Life without Load	实验后 After test: 绝缘电阻 Insulation resistance: Check Insulation resistance as per item 4.1 but Insulation resistance 10MΩ Min. 抗电强度 Dielectric Voltage: Check Dielectric Voltage as per item 4.2	在不带负荷的条件下，在寿命试验设备上连续转换1,000,000次 30-60 次 /分钟。 1,000,000 cycles of operation shall be performed continuously at a rate of 30-60 cycles per minute without load.
6.2	负荷寿命 Operating Life with Load	but Dielectric Voltage :75% item 4.2 note. 操作力变化范围:初期值±30% Operating force range:±30% initial value 开关外观及结构应无损坏 The switch shall be free from abnormalities in appearance and construction.	CQC(GB15092.1)/ENEC(EN61058-1) : 在产品图纸标示负荷的条件下，在寿命试验设备上连续转换 10,0000 次， 15 次/ 分。 CQC(GB15092.1)/ENEC (EN61058-1) 10,0000 cycles of operation shall be performed continuously at a rate of 15 cycles per minute with load as follow: Refer to individual product drawing (Resistive Load)

7. 耐候性能 Weather Proof Characteristics:

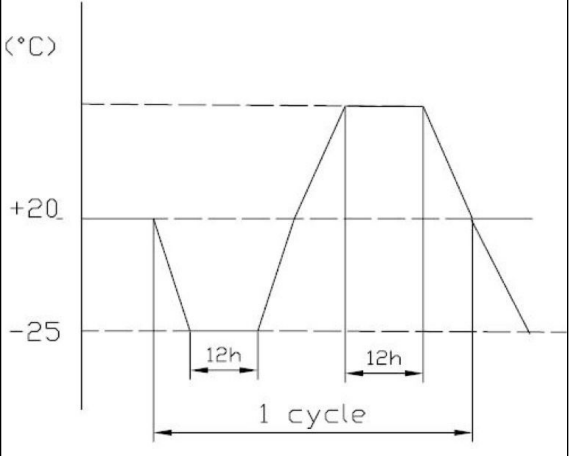
X	项目 Item	标准 Criteria	实验方法 Test Method
7.1	低温 Cold Proof	实验后 After test: 绝缘电阻 Insulation resistance: Check Insulation resistance as per item 4.1 but Insulation resistance 10MΩ Min. 抗电强度 Dielectric Voltage: Check Dielectric Voltage as per item	试件在 -25±3℃ 的温控箱内保持 96 小时，然后在正常温度和湿度下恢复 2 小时，并在此后 1 小时内对试品进行测量，水滴应消失。 After testing at -25±3℃ for 96 hours, the switch can stay under normal temperature and humidity conditions for 2 hours, and measurement shall be made within 1 hour after that. Water drops shall be eliminated.
7.2	高温 Hot Proof	4.2 开关外观及结构应无损坏 The switch shall be free from abnormalities in appearance and construction.	试件在 125±2℃ 的温控箱内保持 96 小时，然后在正常温度和湿度下恢复 2 小时，并在此后 1 小时内对试品进行测量。 After testing at 125±2℃ for 96 hours, the switch can stay under normal temperature and humidity conditions for 2 hours and measurement shall be made within 1 hour after that.
7.3	恒定湿热 Moisture Resistance		试件在 40±2℃，90-95%RH 的温控箱内保持 96 小时，然后在正常温度和湿度下恢复 2 小时，并在此后 1 小时内对试件进行测量，水滴应消失。 After testing at 40±2℃, 90-95% RH for 96 hours, the switch can stay under normal temperature and humidity conditions for 2 hours, and measurement shall be made within 2 hours after that. Water drops shall be eliminated.
7.4	温度转换 Temperature Cycling		试件按下述实验条件试验 4 个循环，然后在正常温度和湿度下恢复 2 小时，并在此后 1 小时内对试品进行测量，水滴应消失。 After 4 cycles of following conditions, the switch can stay under normal temperature and humidity conditions for 2 hours, and measurement shall be made within 1 hour after that. Water drops shall be eliminated. 

7.5	耐焊接热 Solder Resistance	实验后 After test: 绝缘电阻 Insulation resistance: Check Insulation resistance as per item 4.1 抗电强度 Dielectric Voltage: Check Dielectric Voltage as per item 4.2 开关外观及结构应无损坏 The switch shall be free from abnormalities in appearance and construction.	焊接温度 Temperature: Max. 260℃, 焊接时间 Time: 3sec MAX
-----	------------------------	--	---

8.开关材料表 BOM:

序号 No.	零部件名称 Parts Name	数量 Quantity	材料, 规格 Material and Specifications	防火等级 Prevent fire grade	备注 Remarks
1	胶盖 Cover	1	热塑性塑胶	UL94V-0	
2	胶壳 Case	1	热塑性塑胶	UL94V-0	
3	按挚 Plunger	1	热固性塑胶	UL94V-0	
4	COM端子 COM Terminal	1	Cu Alloy		Ag PLATED
5	支杆 Internal lever	1	Cu Alloy		Ag PLATED
6	动片 Moving Plate	1	Cu Alloy		Ag PLATED
7	弹片 Spring	1	Cu Alloy		
8	动片触点 MP Contact	1	AgCu Alloy		
9	NO触点 NO Contact	1	AgCu Alloy		
10	NO端子 NO Terminal	1	Cu Alloy		Ag PLATED
11	手柄 Lever	1	SUS		

注意事项 Precautions for use:

1. 一般事项 General:

本产品主要用于自动化装置, 视觉装置, 家用电器, 信息装置及通讯装置等常用电子设备中; 如果该产品要用于其它具有更高安全性及可靠性的耐久性设备中(如生命维持装置, 宇宙航空装置, 防灾及安全性装置)时, 请确认是否合用, 或者同我方了解详细情况。

The product is used mainly in electronic devices such as automotive devices, visual devices, home electrical appliances, information devices and communication settings. If the products is intended to be used for other endurance equipments requiring highersafetyandreliabilitysuchaslifesupportsystem,spaceandaviationdevices,disasterandsafety system, it's necessary to make verification of conformity or contact us for the details before using.

2. 焊接安装 Soldering and assembly:

(1) 焊锡条件应按照实际的对应条件予以确认。

The soldering conditions should be confirmed according to the actual production environment.

(2) 焊锡工序完成后, 不要尝试用溶剂或类似物品清洗开关。

Don't try to clean the switch with a solvent or similar substance after the soldering process.

(3) 开关焊锡后, 还有热量时, 请不要操作开关。

Don't operate the switch if it still has heat after soldering.

(4) 如使用水溶性助焊剂, 可能会导致开关破损, 因此应确保不要用这种助焊剂。

The switch might be damaged if using the water-soluble flux, so make sure not to use such kind of flux.

3. 安装构造，机械设计 Assembly structure and Mechanical design:

- (1) 线路板上安装孔及安装图示的尺寸都须参照工程图中所建议的尺寸。

The dimensions for the holes and the pattern on PCB should refer to the recommended dimensions on the engineering drawing.

- (2) 如果施超出规定值的较大重力于开关上，会导致开关破损，所以应特别小心防止开关承受超出规定值的较大重力。The switch might be broken if there is stress stronger than the specified is given on it. Take special care not to stress the switch beyond its specification.

- (3) 把本公司的产品和其它产品配合使用时,请客户确认必须适合的规格、法规或规定。另请客户自身确认本公司产品装到客户使用的系统、机械、装置上的适用性.如果想变更开关使用条件，请预先与本公司进行协商。

If the switch is being used together other products, please confirm the compatibility of the specification, laws and regulations. Please also confirm the compatibility of switch to be installed in the systems, machines and devices used by customer. If you want to change the operating conditions of the switch, please consult with us in advance.

4. 使用环境 Operating Environment

- (1) 如果该产品常用于产生硫化气体的硫性热源周围或有汽车废气存在的地方，应特别留意，因为开关性能可能会受到影响；

If the product is always used near sulfurate hot spring where sulfide gas is generated or in a place where exhaust gas from automobiles exists, it's necessary to pay more attention because the switch performance may be affected.

- (2) 如果在安装开关的模组内有以下所描述的部件材料，需遵循以下要求:

If the below parts or materials are used in the module where the switch is installed, directions below should be followed:

- A. 部品、橡胶材料、粘合剂、包装材料及用于装置内机械部件上的润滑油剂等，不要使用那些可能会产生硫化气体或氧化气体的材料。

For parts, rubber materials, adhesive agents, packing material and grease used for the mechanical part of the device, don't use any material that may generate gas of sulfurization or oxidization.

- B. 当有用到磷橡胶、润滑油、粘合剂及油脂时，应使用不会产生低分子磷氧烷气体的材料，因为低分子磷氧烷气体会在开关接触部位形成二氧化磷层而引起接触不良，如有用到（如涂料剂等化学溶剂请预先告知我方。

If silicon rubber, grease, adhesive agents and oil are used, choose the material that will not generate low molecular siloxane gas, because the low molecular siloxane gas may form silicon dioxide coat on the switch contact part, resulting of failing contact.

- (3) 不要将开关用于高湿或有沾湿可能性的环境中，因这样的环境可能会引起端子间电流泄漏。

Don't use the switch in the environment with high humidity or other bedewing possibility, as it may cause leaking among the terminals.

- (4) 外部浸入物的影响:由于该开关无密封机构，因此可能会由于外部环境中浸入的尘埃而引起接触失效，在使用该开关时，应采取防尘措施，以下是尘埃浸入的范例，使用时请注意防止：

The effect caused by outer immersed dust: Because the switch was designed without dust-proof structure, it may have failing contact due to the immersed dust from the outer environment. When using the switch, it's necessary to take dust-proof actions. Examples of immersed dust, which should be prevented during the operation:

- A. 加工过程中切口处及PCB孔处产生碎屑，或PCB防护材料，（如报纸、发泡、聚苯乙烯材料等）产生的废弃物等浸入开关内。

The scraps being generated during PCB processing, or other waste from the protective material for PCB such as newspaper, foam, polystyrene materials, may immerse inside the switch.

- B. 在堆叠 PCB时产生的助焊剂或粉末状焊剂浸入开关内。

The flux or solder powder being generated when stacking the PCB may immerse inside the switch.

5. 保存方法 Storage Method:

- (1) 为防止本产品的性能劣化和耐焊性等性能受到影响，请保管在以下的条件和环境下：

In order to protect the switch performance and the soldering conditions, it should keep the switch under the following conditions:

- A. 温度 -10℃ 以上，+40℃ 以下，湿度85% 以下的环境。
Temperature of -10℃ to +40℃, with humidity lower than 85%RH;
- B. 避免保存在含有腐蚀性气体等的空气中。
Avoid storing in the environment containing corrosive gas;
- C. 产品购入后，长期保管不可超过6个月以上。
After purchasing, the storage period should not exceed 6 months.
- D. 避免保存在日光能直射的场所。
Avoid keeping it in the location with direct sunlight.

- (2) 在不施加负重外力的包装状态下进行保管。

Store using the standard packing without exerting force.

- (3) 保存标准为3个月，限度为6个月以内，请尽早使用。打开包装后，有剩余品时，应将剩余部分以胶袋包装好以同外界隔离，请进行合适的防湿，防腐蚀气体等处理后进行保管。

The standard storage period is 3 months, with maximum up to 6 months, preferably to be used as soon as possible.

After opening the package, you should put the remaining switches in a plastic bag to prevent from damp and corrosive gas.

6. 其它 Others:

请特别注意严格遵守以下的禁止事项及注意事项 Please take good care to comply with the following guidelines:

- (1) 关于火灾，冒烟的禁止事项 The prohibited practices where there is fire and fume:

- A 超过额定负荷使用时，有发生火灾的可能性，故请勿超负荷使用。
It might catch fire if the rating exceeds the specifications. Never use the switch beyond the rating.
- B 如果有误使用、异常使用等有可能超过额定电流的话，请采取对策。如：通过设置保护电路等切断电流。
If the rating may exceed due to some abuse or abnormal usage, please take protective measures such as protective

G5T16-L1P100A01-613

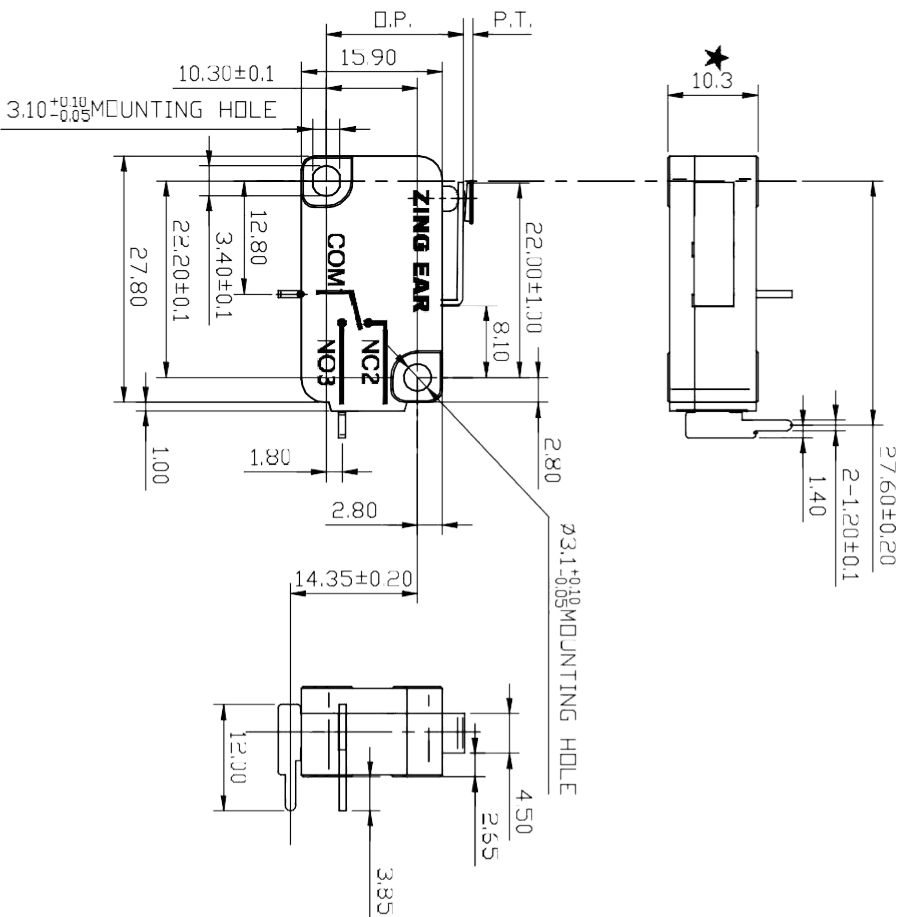

NOTES:
1. MOUNTING HOLES WILL ACCEPT Ø3 MAX PINS OR SCREWS.

CHARACTERISTICS

OPERATING FORCE: **100gf MAX.**
 RELEASE FORCE: **25gf MIN.**
 OPERATING POSITION: **15.3±0.5MM.**
 PRE-TRAVEL: **1.6MM MAX.**
 DIFFERENTIAL TRAVEL: **0.4MM MAX.**
 OVER-TRAVEL: **0.8MM MIN.**

ELECTRICAL DATA

CONTACT ARRANGEMENT
S.P.S.T-NO



16A 1/2HP 125/250VAC

REV	REF	DESCRIPTION	DRAWN BY	DATE

TITLE	GS SERIES OUTLINE DRAWING	rev	A
MODEL	G5T16-L1P100A01-613	FINISH	Xu Jiehui
DATE	2018-1-11	CHK BY	LI Shunqiang
DATE	2018-1-11	SCALE	1:1
DATE	2018-1-11	UNIT	mm

HUIZHOU GRETECH ELECTRONICS CO.,LTD.

1 2 3 4 5 6 7 8 9 10